

IRO AB

Box 54

SE-523 22 Ulricehamn

Sweden

Tel (Int+46) 321 29700

Fax (Int+46) 321 29800

www.iroab.com

info@iro.se

2231 CAN plus



Operating Instructions

Contents.....	1
Technical specifications.....	2
Installation / Mains connection	3
Operating diagram	4
Main parts	5
System orientation	6
Settings	7
N/R rotation - Yarn separation	8
Balloon control/ Threading.....	9
Rotating the spool body.....	10
Maintenance.....	11
Fault finding.....	12-13

WARNING

CAUTION MUST BE TAKEN IN THE CLOSE VICINITY OF THE FEEDER AS IT CONTAINS MOVING PARTS THAT CAN CAUSE INJURIES AND, IN NORMAL OPERATION, STARTS WITHOUT PRIOR WARNING.

THE POWER SUPPLY MUST BE SWITCHED OFF AT THE MAINS BEFORE ANY WORK IS CARRIED OUT ON THE FEEDER, THE TRANSFORMER OR ANY OTHER ELECTRICAL COMPONENTS. THE FEEDER AND THE TRANSFORMER CABINET MUST BE FULLY ASSEMBLED BEFORE THE POWER SUPPLY IS CONNECTED.

THE FEEDER AND TRANSFORMER CONTAIN ELECTRICAL COMPONENTS THAT RETAIN AN ELECTRIC CURRENT UP TO THREE MINUTES AFTER DISCONNECTION.

ALL WORK ON ELECTRICAL COMPONENTS MUST BE CARRIED OUT BY A QUALIFIED ELECTRICIAN.

THIS PRODUCT IS NOT INTENDED FOR USE IN POTENTIALLY EXPLOSIVE ATMOSPHERES OR IN ZONES CLASSIFIED ACCORDING TO THE EUROPEAN DIRECTIVE 94/9/EC. PLEASE CONTACT IRO AB IF PRODUCTS FOR USE IN A POTENTIALLY EXPLOSIVE ATMOSPHERE ARE REQUIRED.

TO COMPLY WITH CE. REGULATIONS ONLY REPLACEMENT PARTS APPROVED BY IRO AB MAY BE USED.

Technical specification

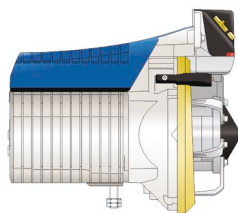

Max 5 300 RPM



8 kg



Min 5° C-Max 40° C



Max 85 %

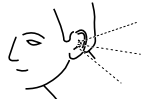

93 dB

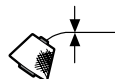

Max 5 mm



5,5 - 7 bar



290V DC, 24V DC



1,3 kg

Installation

NOTE

Condensation can form on the weft feeder when it is moved from the cold environment of the warehouse to the warmer environment of the loom room. Make sure that the feeder is dry before switching it on.

Feeders must be mounted within 40° of the horizontal plane.

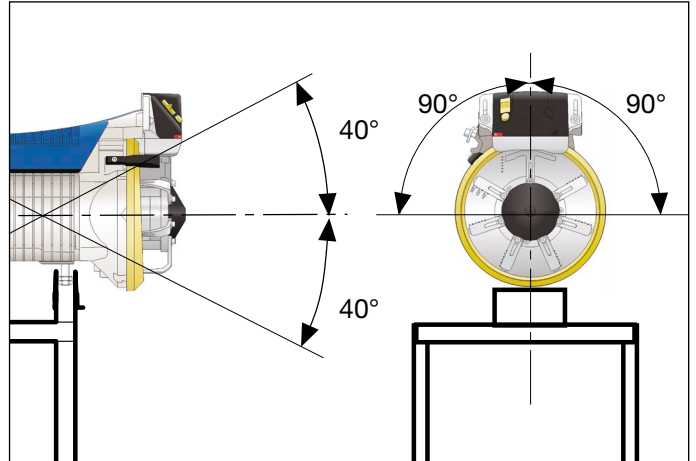

Mains connection

IMPORTANT!

Turn off the main switch before any work is carried out on the electrical circuit.

The power supply to the feeder must not be disrupted when the weaving machine stops.

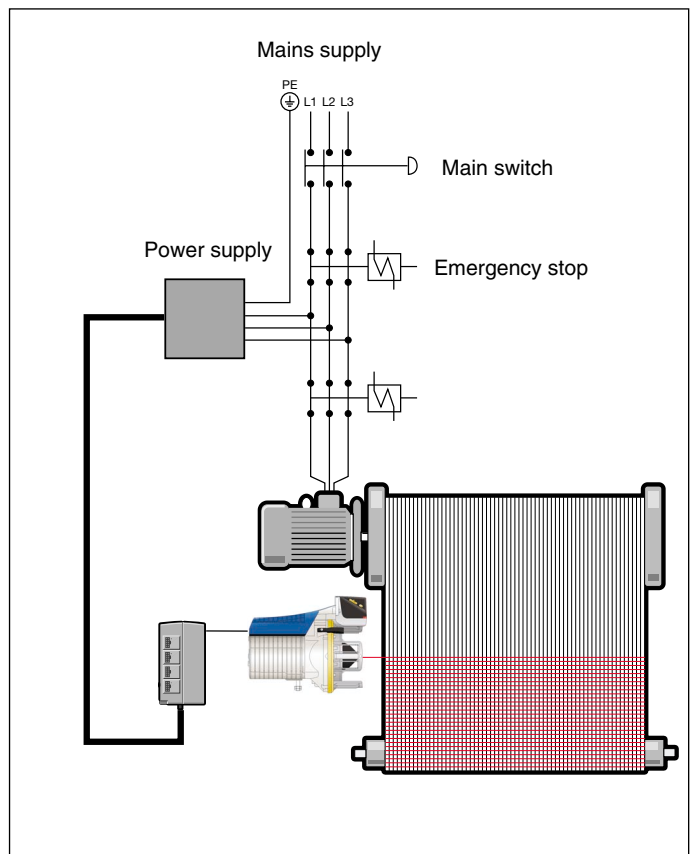

Operating diagram

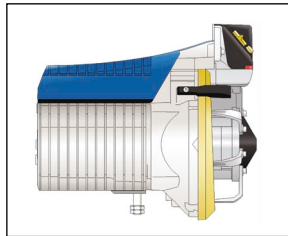

Motor control unit

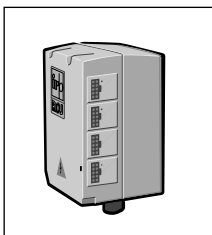

Extension Interface

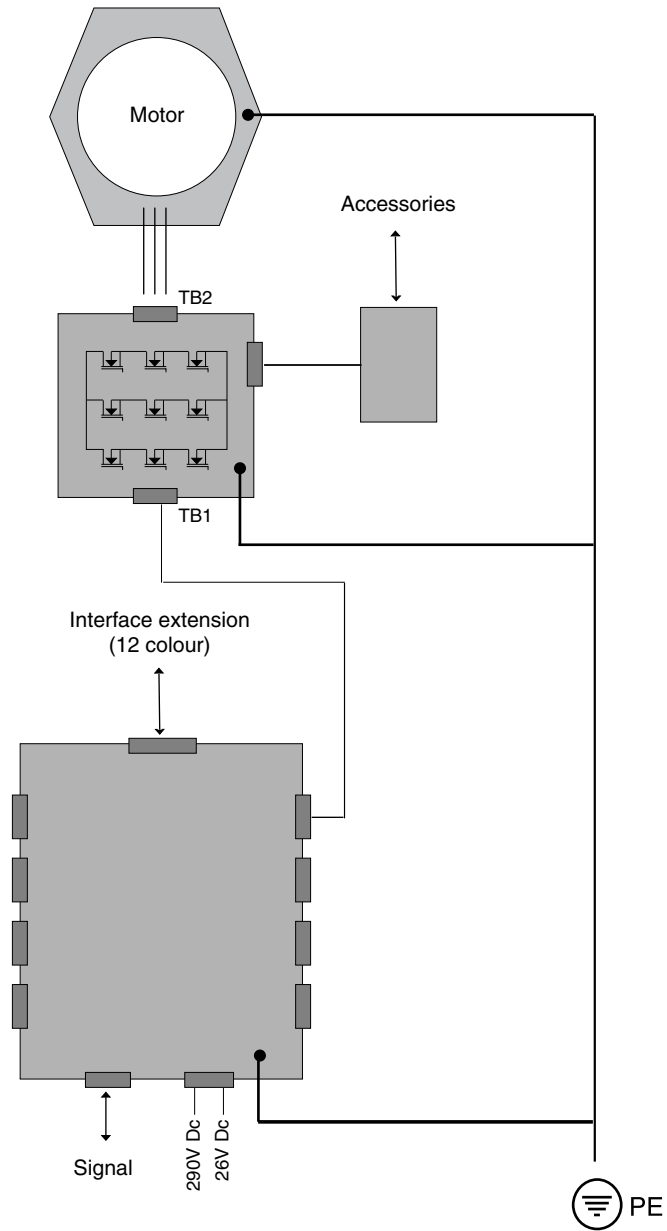

Side view

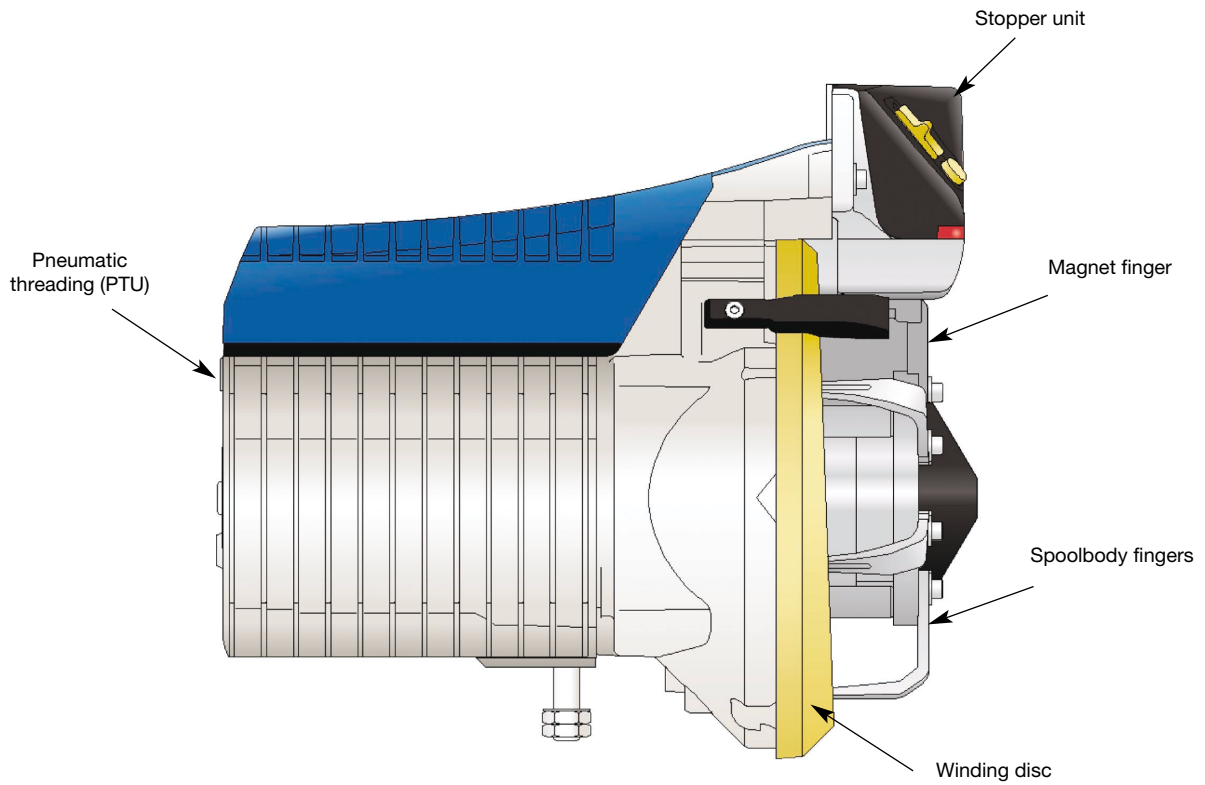

Front view

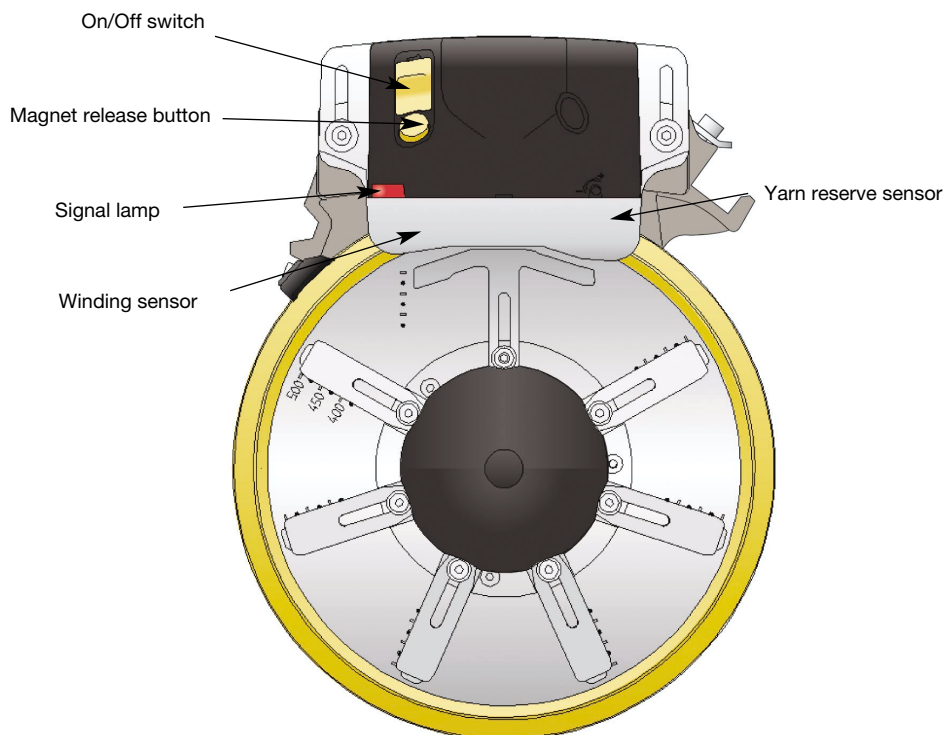

System orientation**SYSTEM**

The system consists of feeders, cables to each feeder, interface control box, PTU (pneumatic threading up), input yarn tensioners and external accessories such as bobbin break sensors and bobbin change detectors.

INTERFACE

This control box handles all communication between feeders and machine via the CAN-bus system. The control box also distributes 290 VDC and 24VDC from the machine to each feeder. An additional extension box is used when more than 8 feeders are connected.

FEEDER

The feeder consists of:

- Motor and control unit.
- Spool body with 7 independantly adjustable fingers.
- Pick length control stopper magnet.
- Yarn store sensor.
- Positioning sensor.
- Winding sensor.

Spool body circumference, yarn store size and stopper unit are mechanically adjusted on the feeder. All other settings are carried out on the weaving machines terminal and transmitted to the feeder through the CAN bus.

The brushless permanent magnet motor is controlled from the control board situated under the top cover.

At feeder start-up, the number of windings on the spool body is controlled by the yarn store sensor which indicates the outer limit of the yarn store. The number of windings supplied to the yarn store is continuously counted by the wind-on sensor whilst at the same time the number of windings removed from the yarn store is counted by the winding sensor. For optimal regulation the pattern information is transferred to each feeder a few picks in advance.

The weft length is equal to the spool body circumference multiplied with number of windings removed during one insertion. The stopper magnet pin is opened at a requested machine-angle by reading the angle-bus and closed directly after the second last winding sensor pulse.

The stopper magnet is driven in both directions electrically, but held in closed position after the power is switched off.

Spool body circumference

The required pick length is the deciding factor when calculating the spool body circumference and the number of windings for each pick. The table below indicates the pick length ranges that can be obtained from different numbers of windings. To calculate the appropriate spool body circumference / number of windings per pick, proceed as follows:

1. Determine the required pick length (drawing-in width plus waste).
2. Check the table below and determine a pick length range that covers the required pick length.
3. The number of windings necessary to obtain the required pick length will be found in the right hand column. If there are two possible values, always choose the lower value. Adjust the spool body to the required circumference as follows:

Pick length range (mm)		No. of Winds
MIN	MAX	
374	508	1
748	1016	2
1122	1524	3
1496	2032	4
1870	2540	5
2244	3048	6
2618	3556	7
2992	4064	8

1. Move the stopper unit to its uppermost position.
2. Loosen the spool body finger retaining screws.
3. Adjust the fingers using the scale on the oscillating disc as a reference.
4. Tighten the finger retaining screws and reposition the stopper unit.
5. Make a weft insertion test and, if necessary, adjust.

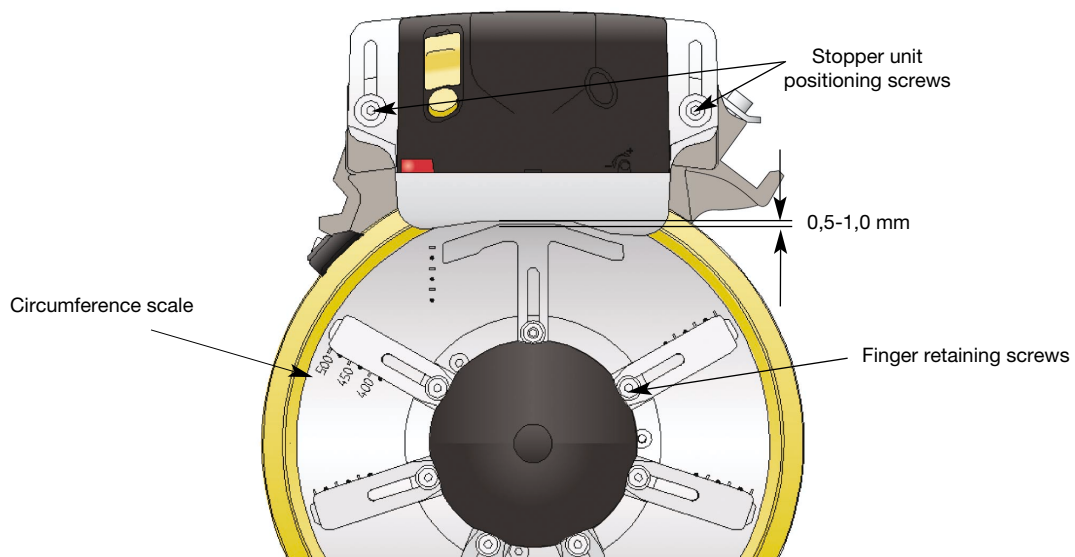

Yarn store

1. The number of windings in the yarn store is regulated by the position of the yarn store sensor.
2. The number of windings needed depends on the weaving machine's speed, the pick length and the pattern. Irregular patterns require larger yarn stores. Increasing yarn store variation will also require an increased yarn store.
3. For optimal performance the yarn store should contain as few windings as possible. It is however important that the yarn store does not run out during high demand peaks. When adjusting always start with a large yarn store and reduce it successively with the yarn store sensor until there are as few windings as possible left during high yarn demand peaks.

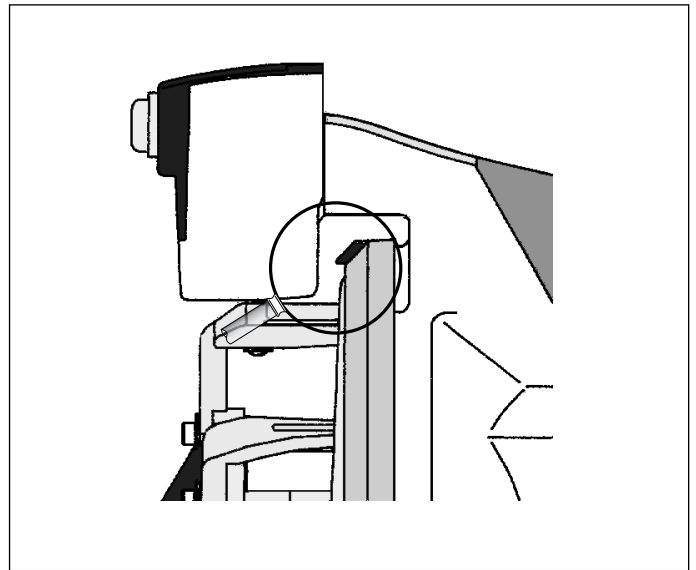

WARNING!! It is important that there is sufficient clearance between the yarn store sensor and the oscillating disc. When weaving with very small yarn stores ensure that the oscillating disc does not touch the sensor after adjustment.

Balloon control

To ensure optimal yarn performance between the feeder and the weaving machine it may be beneficial, especially when weaving heavier yarns, to use a cone for balloon control. During the initial installation the cone should be adjusted to the outermost position, then, with the machine running, slide the cone inwards towards the feeder until the optimum yarn path is obtained. The cone should then be locked into position.

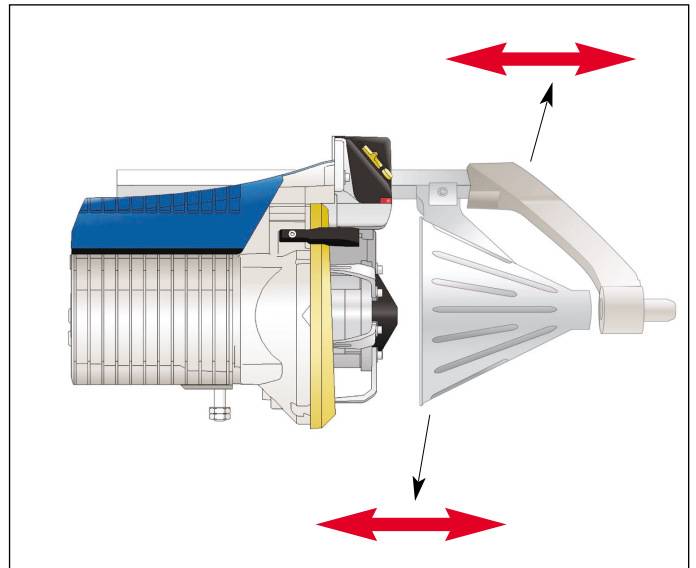

Threading

Before threading the feeder it is necessary to remove any yarn that may be on the spool body. To do this the magnet pin must be opened. This can be performed using any of the following methods:

1. A short push on the yarn release button will release one winding.
2. By pushing the yarn release button and keeping it pushed in the magnet pin will remain open as long as the button is pushed in.

After the magnet pin has been opened any yarn on the spool body can be removed.

To thread the unit proceed as follows:*

1. Hold the end of the yarn close to the input eyelet at the rear of the feeder.
2. Push the PTU activating button and release the yarn.
3. Take hold of the yarn end.
5. Reset the feeder (switch off/on).

* = Full threading: Insure that the yarn eyelet is correctly positioned under the guide (A).

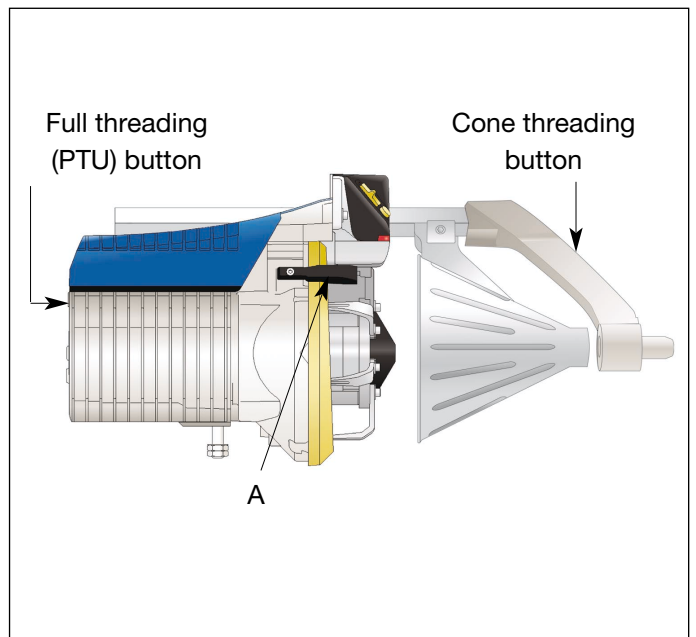

WARNING!!

Failure to follow these instructions will result in damage to the spool body, stopper magnet, stopper magnet pin or the stopper housing

With feeder connected to the weaving machine and machine power on.

Switch off the feeder.

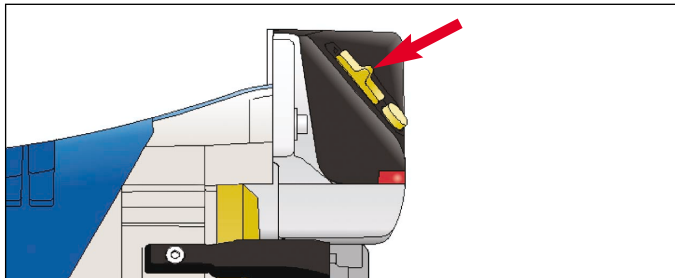

Press the button on the stopper housing and ensure that the magnet pin retracts.

The spool body can be rotated as long as the button is activated.

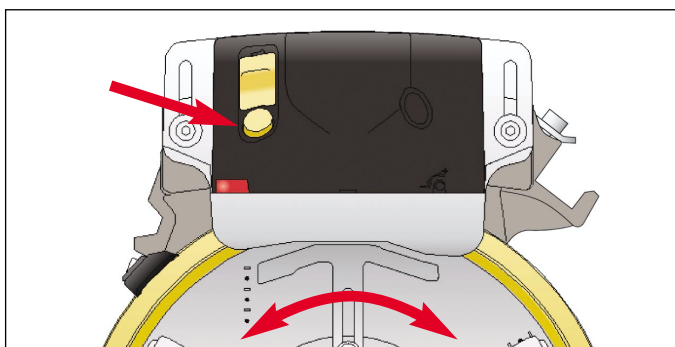

With feeder removed from the weaving machine OR when the power to the weaving machine is switched off.

Remove the two screws retaining the stopper housing.

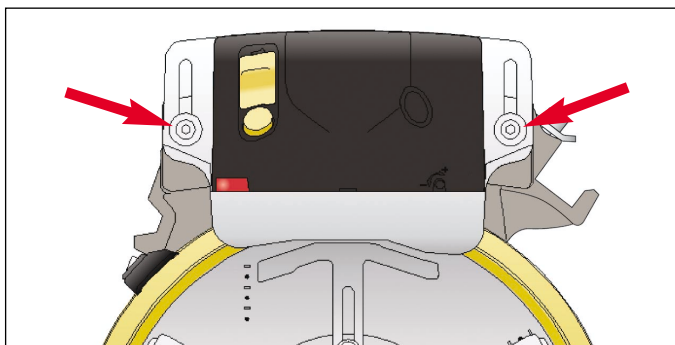

Remove the stopper housing completely.

The spool body can now be rotated as necessary.

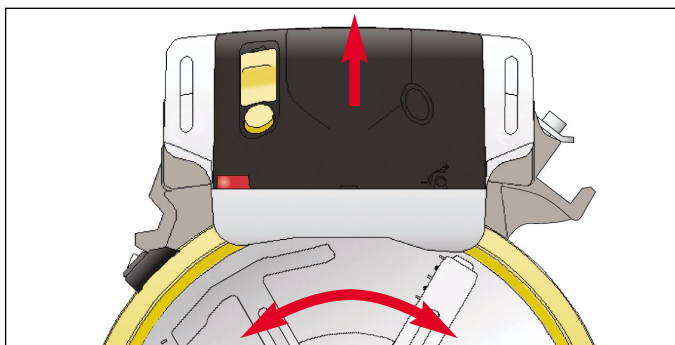

When reassembling the stopper housing it will be necessary to adjust the distance between the magnet and the magnet finger using the guide (see page 7).

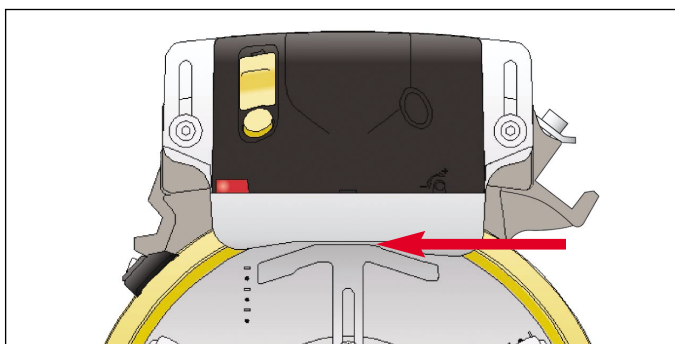

Maintenance

It is recommended to carry out a periodical cleaning of any lint or dust accumulation on the feeder or the control box.

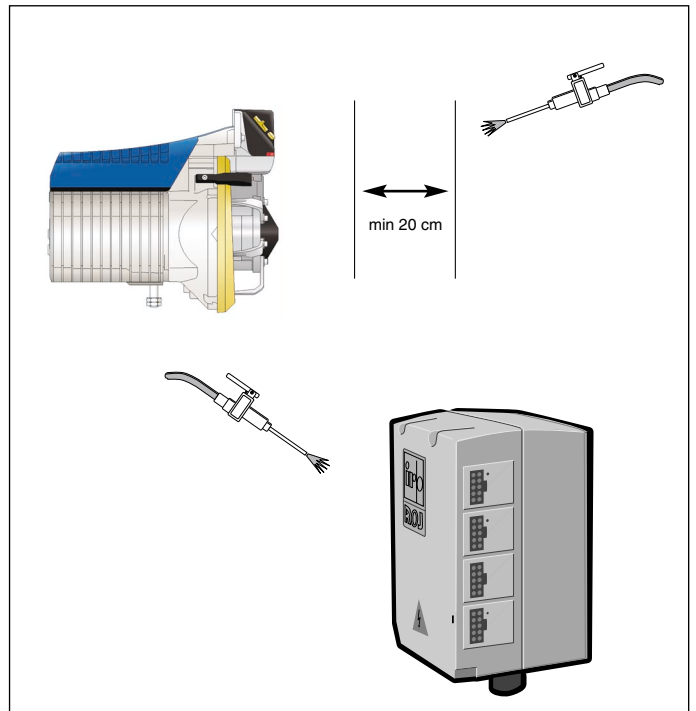

The unit requires no extra lubrication.

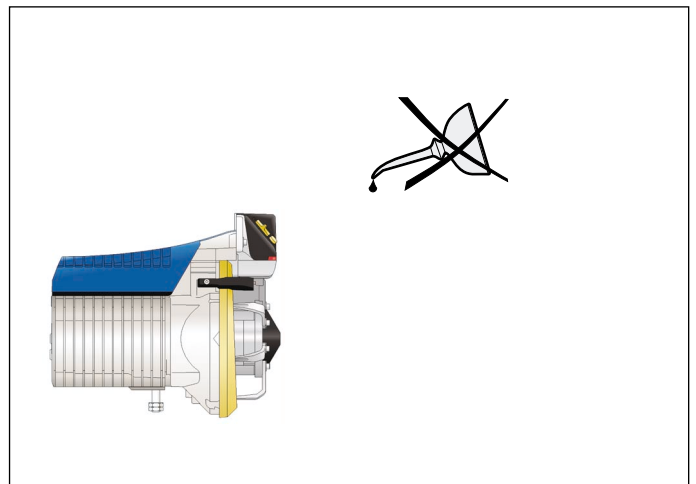

IMPORTANT!

The connector cover must be assembled.

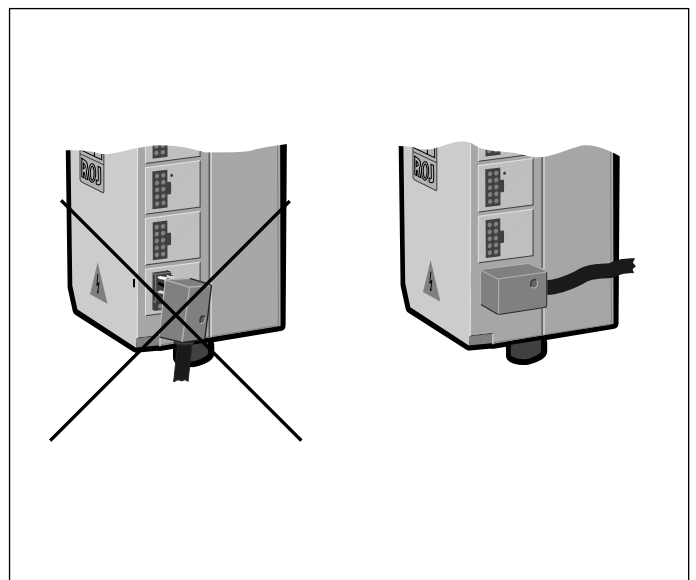

Voltage check

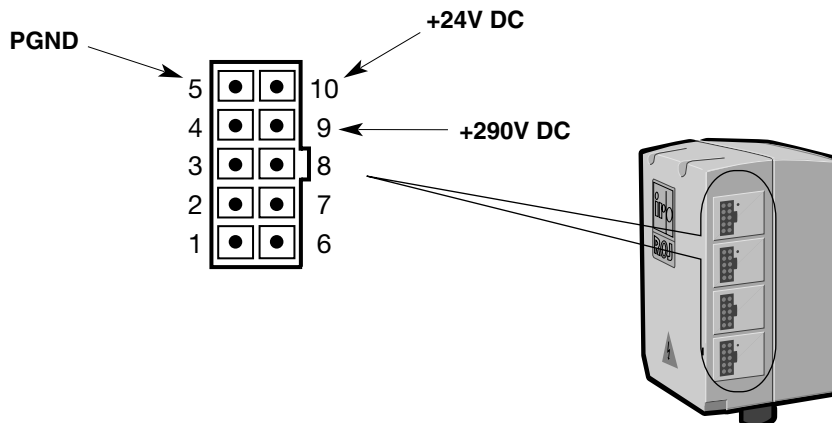

Interface check

Code switch settings



CAN enabled

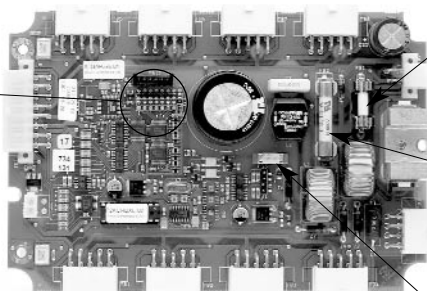

Fuse T5A/ 250 V
24V DC for feeder
and communication
feeder size

Fuse T3,15A/ 500V
290V DC,
feeder motor

Fuse T0,75A/ 250V
24V DC. for
communication
(loom side)

Feeder check

Stopper magnet connector

Coil resistance:
Yellow- Blue \approx 65 Ohm
Red- Green \approx 65 Ohm

Motor connector

Coil resistance:
Yellow- Red \approx 8 Ohm
Yellow- Green \approx 8 Ohm
Green- Red \approx 8 Ohm

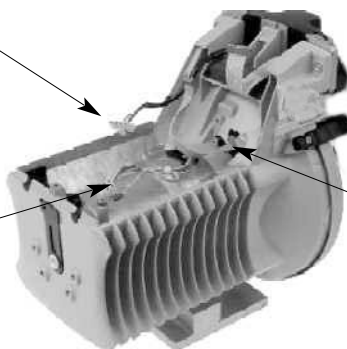

Positioning sensor (proximity switch)

Make sure that sensor is mounted close to motor housing for reliable function.

Fault finding

Type of problem	Check in the following order
Feeder motor does not start when ON/ OFF switch is ON - Feeder LED Off.	19-20-8-1-2-3
Feeder motor does not start when ON/ OFF switch is ON - Feeder LED On.	21-10-9-5-4
Feeder LED indicates error (double blinking).	5-6-26-27
Feeder LED indicates error (blinking).	29-10-17-22
Feeder stopper magnet does not open.	1-7-8-26-24-25
Input yarn breaks frequently.	18
Feeder does not fill up yarn properly.	21-10-23-24
Feeder does not stop (over filling).	10-21-23-24
Loom terminal indicates "Blocked rotor".	5-6
Communication failure between loom and feeder.	2-3-24-25
Feeder 1131 CAN Plus is displayed as 2231 CAN Plus at loom terminal.	8-23-24
Frequent problems with long or short picks.	11-28-23-24
Feeder indicates bobbin break but the yarn is not broken.	17-22-12
Feeder does not stop at yarn break.	15-13-24-22

Possible causes	Remedies
1. Switch failure	Replace stopper housing cover.
2. Fuses blown - Feeder	Check fuse. If broken, replace circuit board.
3. Fuses blown - Interface	Check fuse. If broken, replace fuse or circuit board.
4. Motor stator damaged	Check stator resistance with Ohm-meter.
5. Rotor blocked	Check if the winding disc rotates freely.
6. Rotation sensor not connected connected to the circuit board.	Check that the rotation sensor connector is properly connected to the circuit board.
7. Magnet not connected	Check that the magnet connector is properly connected to the circuit board.
8. Sensor board not connected	Check that the sensor board connector is properly connected to the circuit board.
9. Motor not connected to the circuit board	Check that the motor connector is properly connected.
10. Wrong reserve sensor settings	Adjust sensor sensitivity settings (loom terminal).
11. Wrong winding sensor settings	Adjust sensor sensitivity settings (loom terminal).
12. Wrong yarn-break sensor settings	Adjust sensor sensitivity settings (loom terminal).
13. Yarn break sensor not activated	Activate yarn break sensor (loom terminal).
14. Yarn break sensor not connected	Connect yarn break sensor.
15. External sensor selected, but not installed	Set "internal" yarn break sensor (loom terminal) or install external sensor.
16. Yarn break sensor set to "internal"	Set "external" yarn break sensor (loom terminal).
17. Input yarn tension too low	Adjust input tensioner.
18. Input yarn tension too high	Adjust input tensioner.
19. Loom main power off	Switch loom "main power" on.
20. Loom "stand by" switch off	Switch "stand by" on.
21. Feeder not clean	Remove dust and fibres, clean sensor window (see page 10).
22. Sensor not clean	Remove dust and fibres, clean sensor window and mirror (see page 10).
23. Sensor damaged	Replace sensor.
24. Motor circuit board damaged	Replace motor circuit board.
25. Interface board damaged	Replace interface circuit board.
26. Power failure	290V/ 24V DC failure. Check interface and feeder fuses, check voltage level.
27. Feeder motor failure	Check feeder motor coil resistance.
28. Incorrect distance between fixed finger and stopper unit	Adjust gap.
29. Yarn break indication	Rethread feeder.